

Warning:

This product must be installed by personnel who are familiar with its structure and related hazards, in accordance with the installation specifications. This product is suitable for indoor installation.

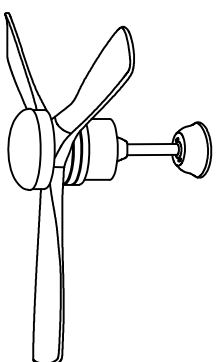

Steps of installation

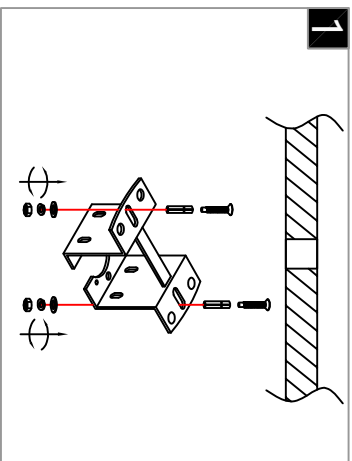

1 Fix the mounting bracket to the ceiling.

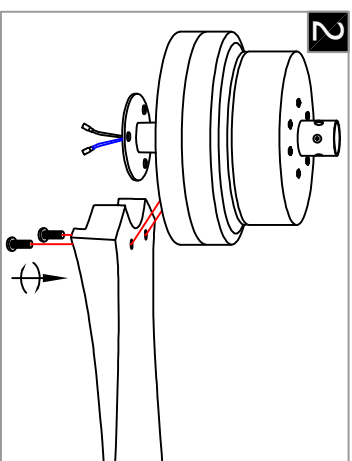

2 Align the fan blades with the holes at the bottom of the cover, and tighten the screws.

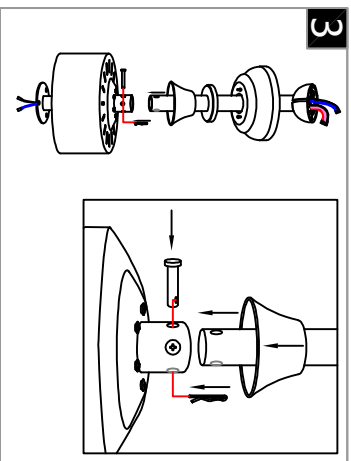

3

Pass the round tube through the top cover, flat base cover, conical cover, and the wires, insert it into the cylindrical part of the motor, align the holes, insert the lock pin, then insert the pin into the lock pin, tighten the screws, and then press down and cover the conical cover.

Product style diagram

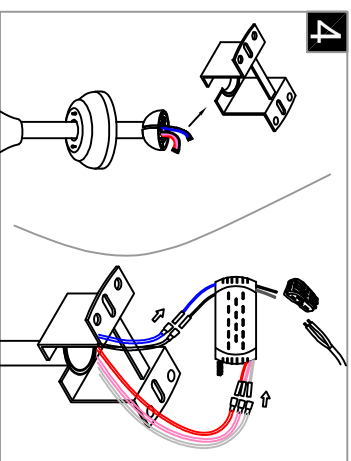

4

Insert the round tube into the installation bracket, (aligning the concave and convex positions), then connect the wires of the power driver and the wires coming out of the round tube, and connect the wires on the ceiling using the terminal.

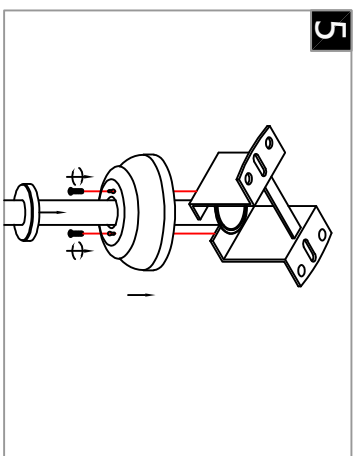

5

Align the holes of the top cover with the holes at the bottom of the mounting bracket, tighten the screws. Then attach the flat base cover to the top cover, covering the screws.

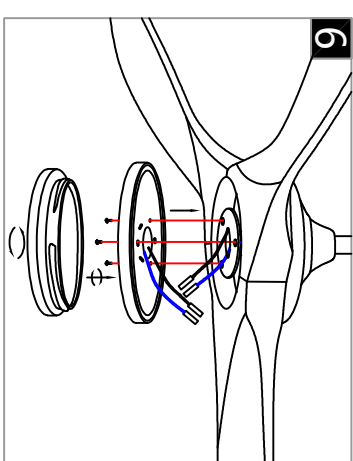

6

Align the holes of the disc with the screw holes of the bottom round piece of the motor, and tighten the screws. Adhere the light source to the disc, and then connect the light source wires to the wires of the motor. Finally, rotate and tighten the lampshade onto the disc.

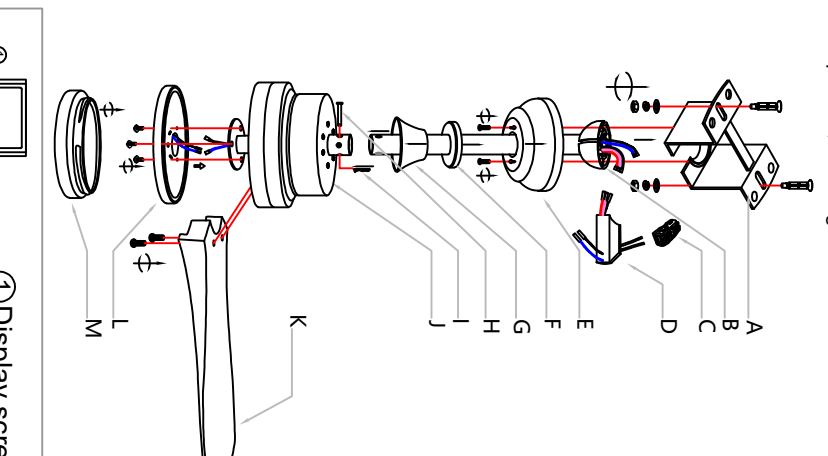

First, align the fan blades (K) with the screw holes at the bottom of the motor (J), and tighten the screws. Then, pass the round tube (B) through the top cover (E), flat base cover (F), conical cover (G), and the wires, insert it into the cylindrical part of the motor (J), align the holes, insert the lock pin (H), then insert the pin (I) into the lock pin (H), tighten the screws, and then press down and cover the conical cover (G).

Next, fix the mounting bracket (A) to the ceiling. Then, insert the round tube (B) into the mounting bracket (A) (make sure the concave and convex positions are aligned), and connect the power wire (D) to the wire of the round tube (B), and connect the power wire (D) to the wires on the ceiling through the quick connector (C).

Finally, align the holes of the top cover (E) with the holes at the bottom of the mounting bracket (A), tighten the screws. Then attach the flat base cover (F) to the top cover, covering the screws.

Next, align the holes of the disc (L) with the screw holes of the circular part at the bottom of the motor (J), and tighten the screws. Attach the light source to the disc (L), and then connect the wire of the light source to the wire of the motor (J). Finally, rotate and tighten the lampshade (M) onto the disc (L).

① Display screen

② Light on / Light off

③ Fan speed 1 settings

④ Fan speed 3 settings

⑤ Fan speed 5 settings

⑥

⑦ FAN/OFF

⑧ Fan speed 2 settings

⑨ Fan speed 4 settings

⑩ Fan speed 6 settings

⑪

