

Warning:
This product must be installed by personnel who are familiar with its structure and related hazards, in accordance with the installation specifications. This product is suitable for indoor installation.

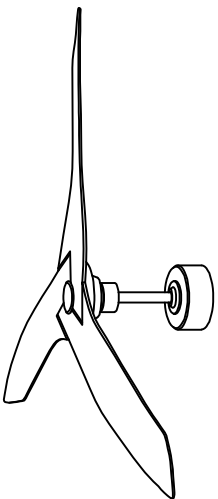

Steps of installation

1

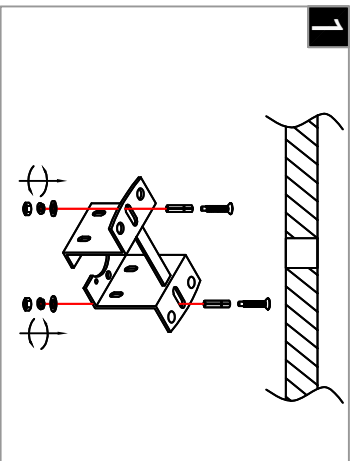

Fix the mounting bracket to the ceiling.

2

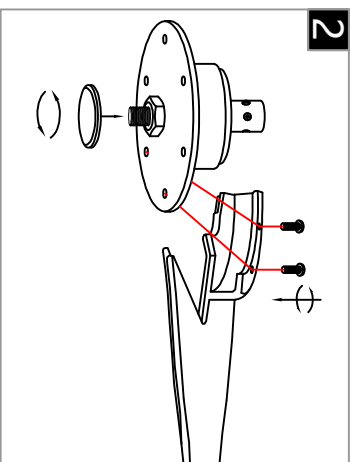

Align the fan blades with the holes at the bottom of the mounting bracket, then install the elliptical cover onto the threaded rod in the middle of the motor.

5

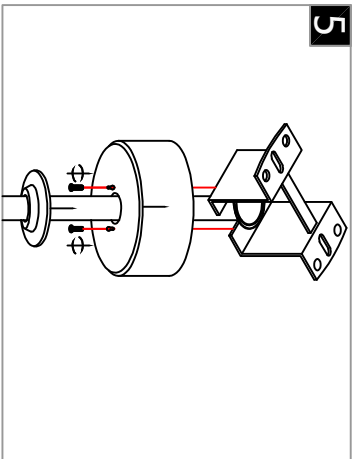

Align the holes of the top cover with the holes at the bottom of the mounting bracket, tighten the screws. Then push the conical cover onto the top cover to cover the screws.

First, align the fan blades (K) with the screw holes around the motor (J) and tighten the screws. Then, install the elliptical cover (L) onto the threaded rod in the middle of the motor (J).

Next, pass the round tube (B) through the top cover (E), the conical cover (F), the flat cover (G), and the wires, insert it into the cylindrical part of the motor (J), align the holes, insert the lock pin (H), then insert the pin (I) into the lock pin (H), tighten the screws, and press and cover the conical cover (G).

Then, fix the mounting bracket (A) to the ceiling.

Next, insert the round tube (B) into the mounting bracket (A) (make sure the concave and convex positions are aligned), connect the power wire (D) to the wire of the round tube (B), and then connect the power wire (D) to the wires on the ceiling through the quick connector (C).

Finally, align the holes of the top cover (E) with the holes at the bottom of the mounting bracket (A), tighten the screws. Then push the conical cover (F) onto the top cover (E) to cover the screws.

3

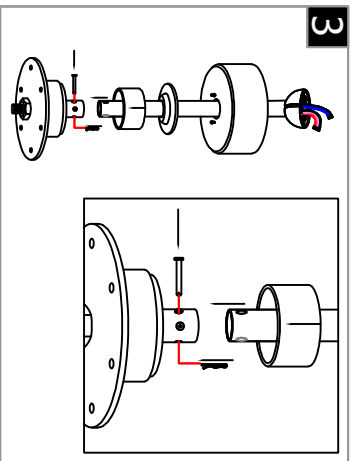

Pass the round tube through the top cover, flat base cover, conical cover, and the wires, insert it into the cylindrical part of the motor, align the holes, insert the lock pin, then insert the pin into the lock pin, tighten the screws, and then press down and cover the conical cover.

4

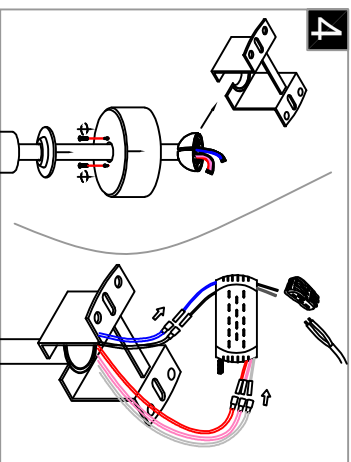

Insert the round tube into the installation bracket, (aligning the concave and convex positions), then connect the wires of the power driver and the wires coming out of the round tube, and connect the wires of the power driver and the wires on the ceiling using the terminal.

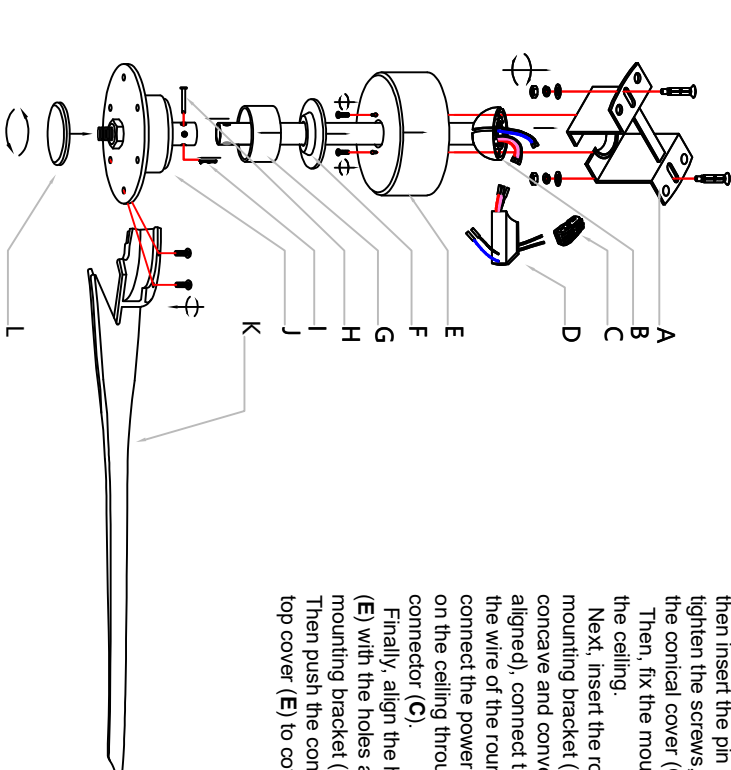

- ① ALLOFF
- ② Forward
- ③ FAN Speed control gears 1-6
- ④ FAN 1-hour Timer
- ⑤ LIGHT ON/OFF
- ⑥ Natural Wind Mode
- ⑦ Reverse
- ⑧ FAN/OFF
- ⑨ FAN 4-hour Timer
- ⑩ FAN 2-hour Timer