

Warning:
This product must be installed by personnel who are familiar with its structure and related hazards, in accordance with the installation specifications. This product is suitable for indoor installation.

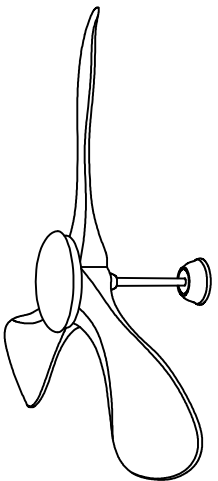

Steps of installation

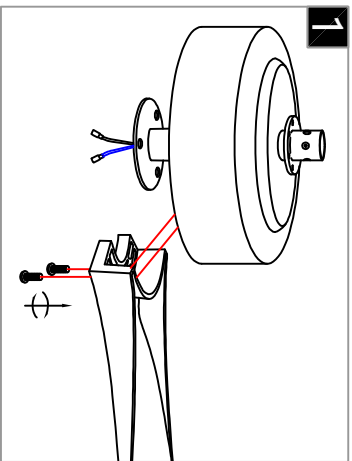

1 Align the fan blades with the holes at the bottom of the cover , and tighten the screws.

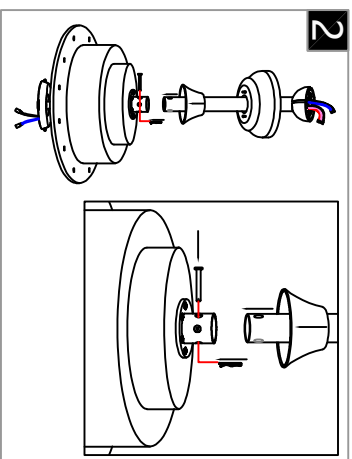

2 Pass the round tube through the top cover , the horn cover , and the wires, insert it into the cylinder on the lamp body . align the hole positions, insert the lock pin , then insert the pin into the lock pin, tighten the screws, and press the horn cover downward to cover it.

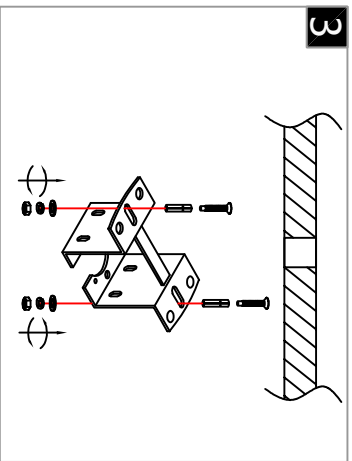

3 Fix the mounting bracket to the ceiling.

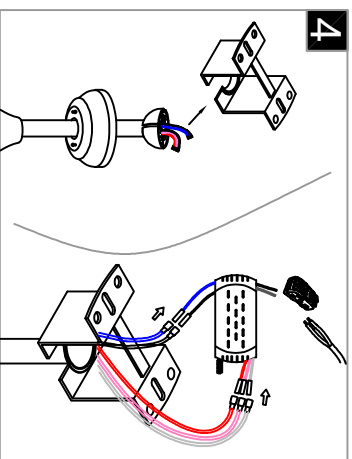

4 Insert the round tube into the installation bracket , (aligning the concave and convex positions), then connect the wires of the power driver and the wires coming out of the round tube , and connect the wires of the power driver and the wires on the ceiling using the terminal .

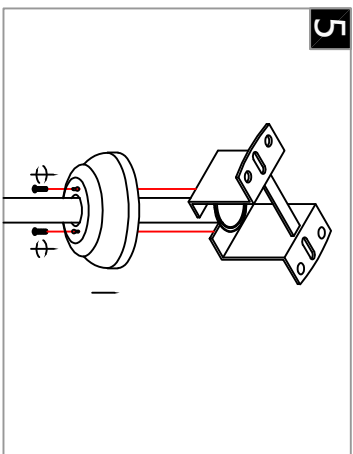

5 Align the holes of the top cover with the holes at the bottom of the installation bracket , tighten the screws.

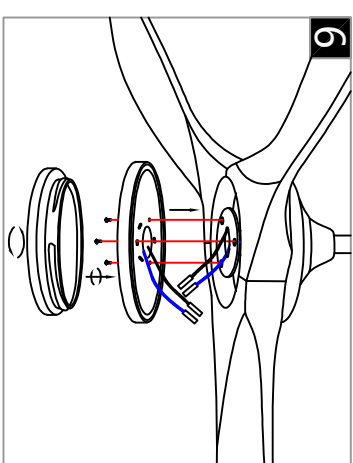

6 Align the holes of the disc with the screw holes of the bottom round piece of the motor , and tighten the screws. Adhere the light source to the disc , and then connect the light source wires to the wires of the motor . Finally, rotate and tighten the lampshade onto the disc.

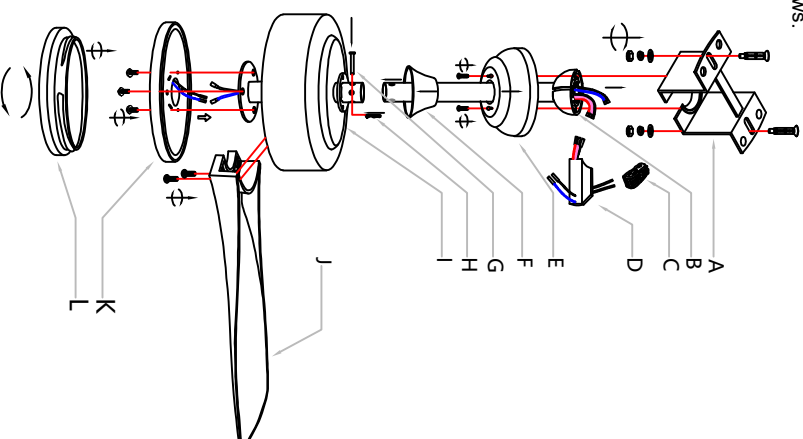

First, align the fan blades (J) with the screw holes at the bottom of the motor (I) and tighten the screws.

Then, pass the round tube (B) through the top cover (E), the conical cover (F), and the wires, insert it into the cylindrical part of the motor (I), align the holes, insert the lock pin (G), then insert the pin (H) into the lock pin (G), tighten the screws, and then press down the conical cover (E) and cover it. Next, fix the installation bracket (A) to the ceiling.

Then, insert the round tube (B) into the installation bracket (A) (make sure the concave and convex positions are aligned), then connect the power supply (D) wires to the wires of the round tube (B), and connect the power supply (D) wires to the wires on the ceiling through the quick connector (C).

Finally, align the holes of the top cover (E) with the holes at the bottom of the installation bracket (A), tighten the screws.

Then, align the holes of the disc (K) with the screw holes of the bottom round piece of the motor (I), and tighten the screws. Adhere the light source to the disc (K), and then connect the light source wires to the wires of the motor (I). Finally, rotate and tighten the lampshade (L) onto the disc (K).

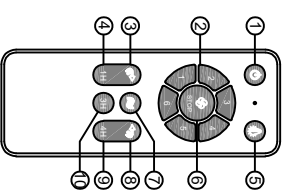

- ① ALLOFF
- ② FAN Speed control gears 1-6
- ③ Forward
- ④ FAN 1-hour Timer
- ⑤ LIGHT ON/OFF
- ⑥ FAN/OFF
- ⑦ Natural Wind Mode
- ⑧ Reverse
- ⑨ FAN 4-hour Timer
- ⑩ FAN 3-hour Timer