

Warning:

This product must be installed by personnel who are familiar with its structure and related hazards, in accordance with the installation specifications. This product is suitable for indoor installation.

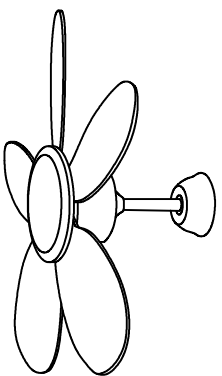

Product style diagram

1 Steps of installation

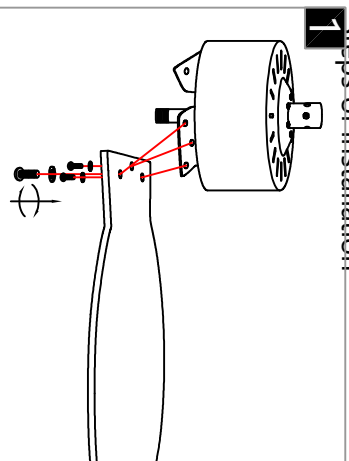

Align the fan blades with the bottom of the motor , the screw holes of the fan blade bracket, and then tighten the screws.

2

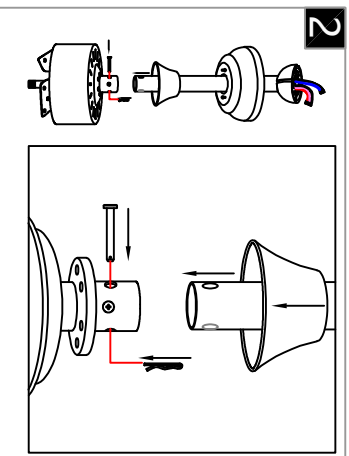

Pass the round tube through the top cover , the horn cover , and the wires, insert it into the cylinder on the lamp body . align the hole positions, insert the lock pin , then insert the pin into the lock pin , tighten the screws, and press the horn cover downward to cover it.

3

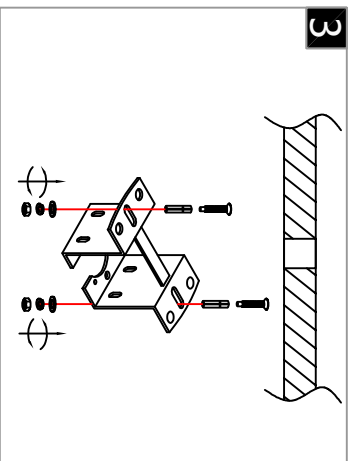

Fix the mounting bracket to the ceiling.

5

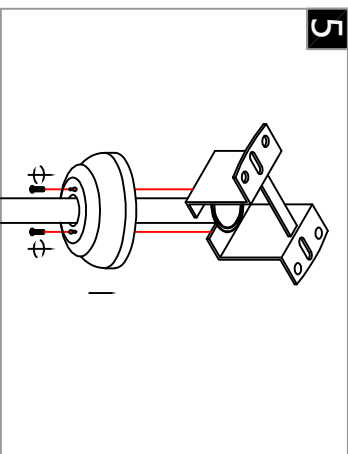

Align the holes of the top cover with the holes at the bottom of the installation bracket , tighten the screws.

6

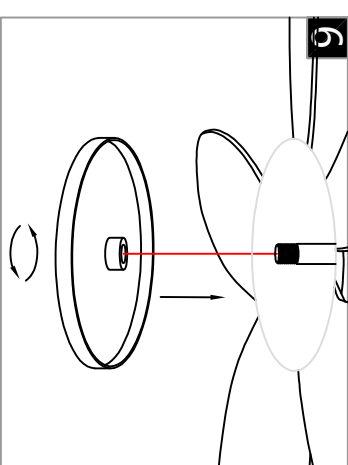

Align the disc with the threaded rod in the middle of the motor , rotate the disc to lock it.

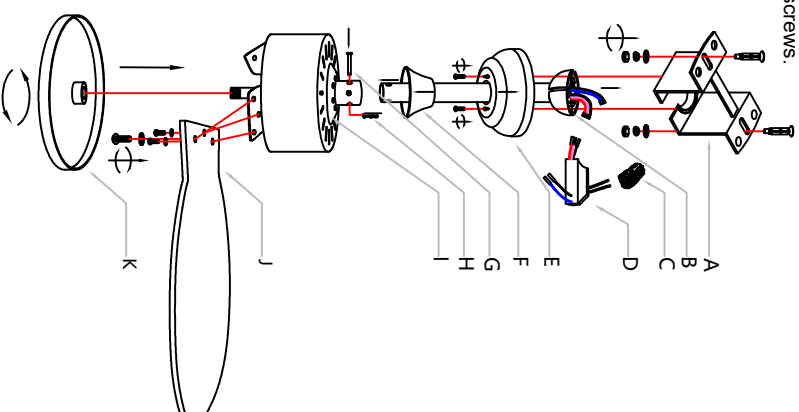

4

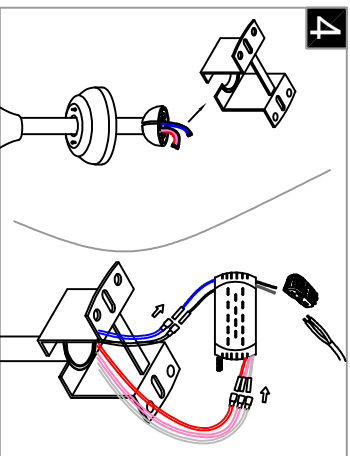

Insert the round tube into the installation bracket , (aligning the concave and convex positions), then connect the wires of the power driver and the wires coming out of the round tube , and connect the wires of the power driver and the wires on the ceiling using the terminal .

First, align the fan blades (J) with the bottom of the motor (I), the screw holes of the fan blade bracket, and then tighten the screws.
Next, pass the round tube (B) through the top cover (E), the conical cover (F), and the wires, insert it into the cylindrical part of the motor (I), align the holes, insert the lock pin (G), then insert the pin (H) into the lock pin (G), tighten the screws, and then press down the conical cover (E) and fix it.
Then, fix the installation bracket (A) to the ceiling.
Next, insert the round tube (B) into the installation bracket (A) (make sure the concave and convex positions are aligned), connect the power line (D) to the conductor of the round tube (B), and connect the power line (D) to the conductor on the ceiling through the quick connector (C).
Finally, align the holes of the top cover (E) with the holes at the bottom of the installation bracket (A), tighten the screws.
Then, align the disc (K) with the threaded rod in the middle of the motor (I), rotate the disc to lock it.

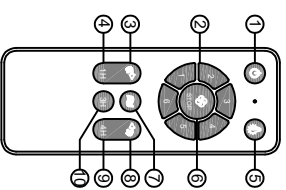

- ① ALLOFF
- ② FAN Speed control gears 1-6
- ③ Forward
- ④ FAN 1-hour Timer
- ⑤ LIGHT ON/OFF
- ⑥ FAN/OFF
- ⑦ Natural Wind Mode
- ⑧ Reverse
- ⑨ FAN 4-hour Timer
- ⑩ FAN 3-hour Timer