

Warning:
This product must be installed by personnel who are familiar with its structure and related hazards, in accordance with the installation specifications. This product is suitable for indoor installation.

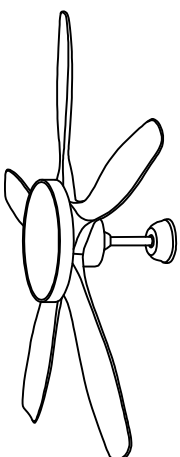

Product style diagram

Steps of installation

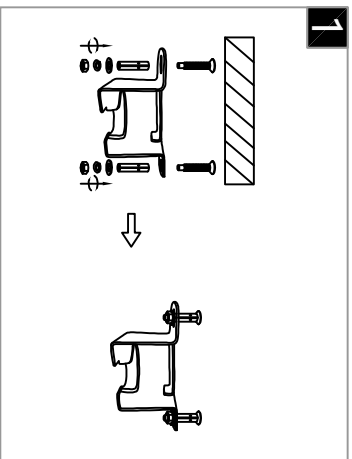

Note: The ceiling must be able to bear a weight of 20 IBS. Then, follow the steps below to fix the mounting plate onto the ceiling.

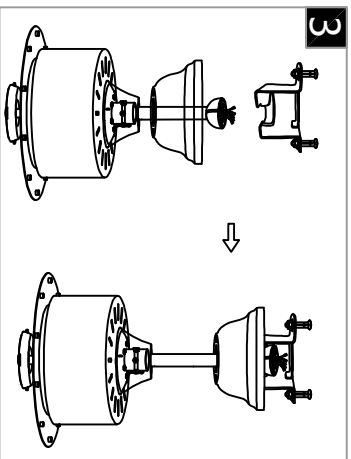

Insert the connection rods of the lamp body into the suspension bracket one by one, then put the power driver into the top cover, and insert the reserved driving wire into the connection rods.

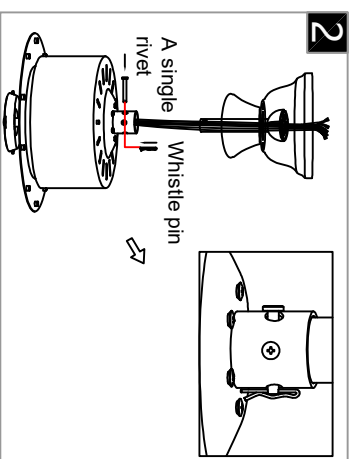

Insert the wires on the motor from the connecting rod into the driver by color, then press the entire lamp body onto the motor, insert the iron pin, and tighten the screw.

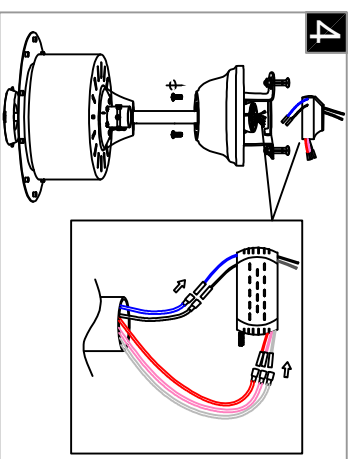

Insert the connection rods of the lamp body into the mounting plate one by one, then put the power driver into the top cover, and insert the reserved driving wire into the connection rods.

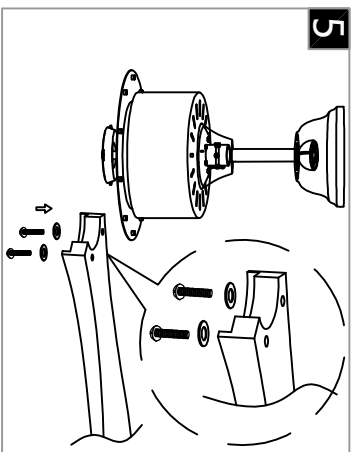

Lock the fan blades onto the fan motor according to their serial numbers, paying attention to the front and back of the fan blades. Then lock the screws.

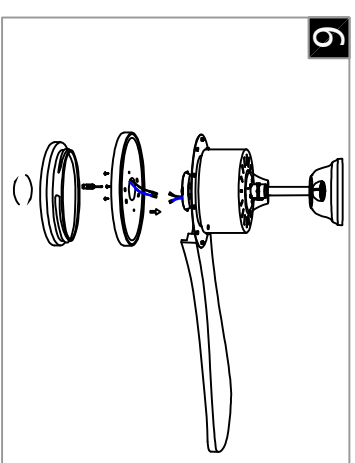

Connect the wires on the light source cover to the wires on the motor by color, align the screw holes on the motor with the light source cover, and then fix the screws with a screwdriver. Then twist the acrylic lampshade clockwise over the light source lampshade.

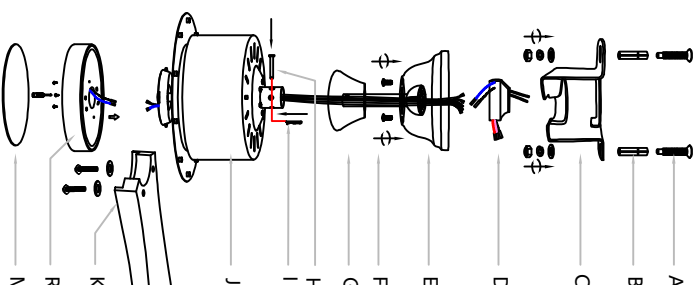

Attach the fan blades (K) to the motor (J) using screws and washers, then insert the wires into the motor (J) above the disc (R) according to their colors. Next, align the holes on the disc (R) with those on the motor (J), tighten the screws, and then insert the lampshade (M) into the disc (R). Then, align the opening of the motor (J) with the bottom of the lampshade (E) using the connecting rod (F), and pass the wires through the bottom cover (G) and the connecting rod (F) and insert them into the top cover (E). Then, align the holes of the connecting rod (F) and the motor (J) with the screws using the pin (H), and insert the pin (I) into the iron nail (H). Next, cover the screw (A) with the iron nail (B), then screw it into the ceiling. Then, align the screw (B) with the hole (C) on the mounting plate (C), and lock it using a nut and a washer. Finally, use the head of the lamp body connecting rod (F) to suspend the lamp body onto the mounting plate (C), and connect the wires on the lamp body to the power driver (D). Connect the neutral wire and the live wire above the power driver (D) to the wires above the ceiling according to their colors. It is best to align the holes at the bottom of the top cover (E) with the holes on the mounting plate (C), and then tighten the screws.

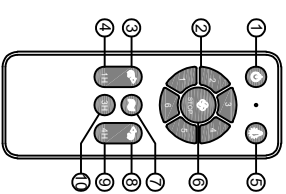

- ① ALLOFF
- ② FAN Speed control gears 1-6
- ③ Forward
- ④ FAN 1-hour Timer
- ⑤ LIGHT ON/OFF
- ⑥ FAN/OFF
- ⑦ Natural Wind Mode
- ⑧ Reverse
- ⑨ FAN 4-hour Timer
- ⑩ FAN 3-hour Timer