

Warning:

This product must be installed by personnel who are familiar with its structure and related hazards, in accordance with the installation specifications. This product is suitable for indoor installation.

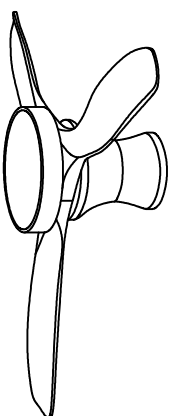

Product style diagram

Steps of installation

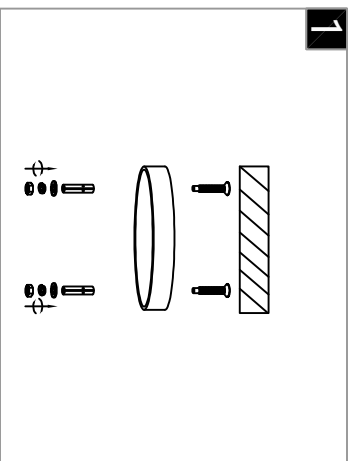

Note: The ceiling must be able to bear a weight of 20 LBS. Then, follow the steps below to fix the mounting plate onto the ceiling.

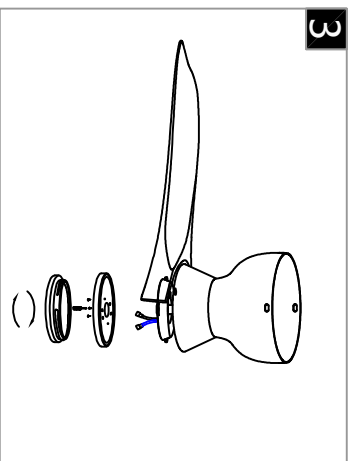

Connect the wires on the light source cover to the wires on the motor by color, align the screw holes on the motor with the light source cover, and then fix the screws with a screwdriver. Then twist the acrylic lampshade clockwise over the light source lampshade.

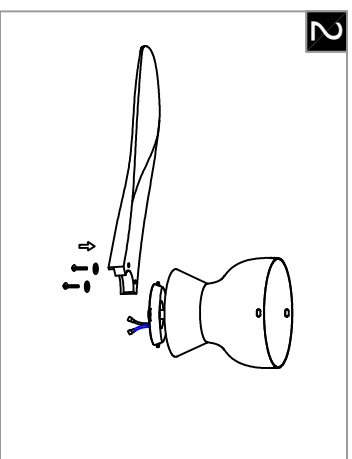

Install the fan blades by screwing on the washers and attaching them to the motor.

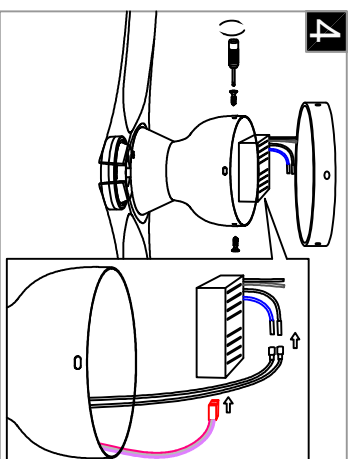

Then connect the drive power supply and the motor reserve line together, and then connect it to the reserve line on the ceiling and to the terminal block. Finally, fix the overall top cover position onto the installation plate.

Install the fan blades (F) onto the motor (G) using screws and washers. Then, insert the color of the wires on the motor (G) into the slot inside the light source cover (H). Next, align the holes on the light source cover (H) with those on the motor (G), tighten the screws, and then screw the light source cover (I) clockwise into the light source cover (H). Then, connect the reserved wires to the power supply (D), and connect the reserved wires on the power supply (D) to the reserved wires on the mounting plate to the terminal (C). Insert the metal nails into the ceiling with nails, align the screws (A) with the mounting plate (B), and lock them with nuts and washers. Finally, align the position of the light source cover (E) of the lamp body onto the mounting plate (B), and tighten the screws on both sides.

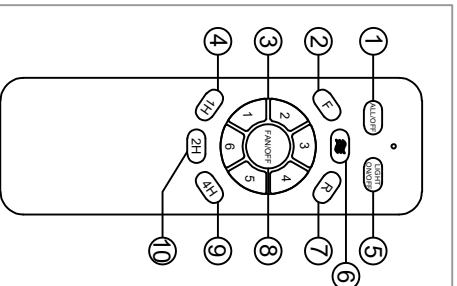
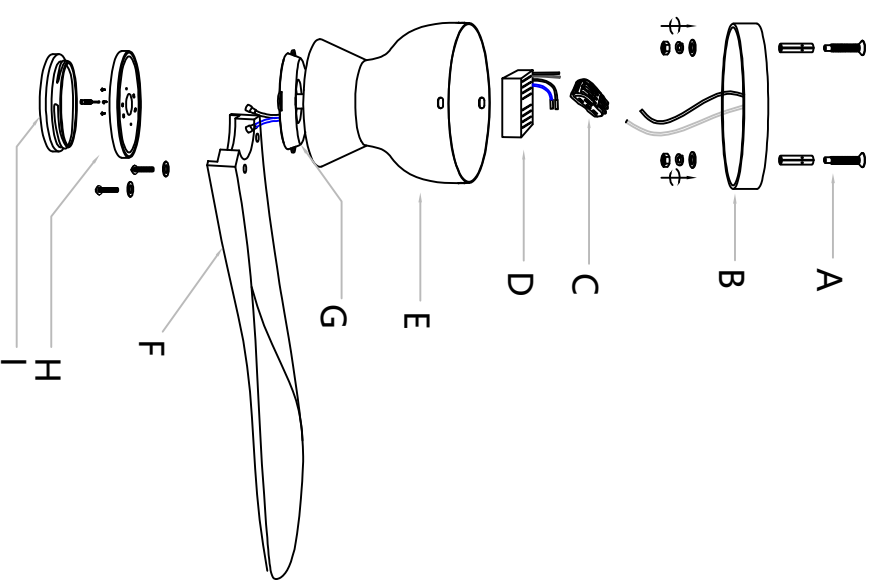

- ① ALLOFF
- ② Forward
- ③ FAN Speed control gears 1-6
- ④ FAN 1-hour Timer
- ⑤ LIGHT ON/OFF
- ⑥ Natural Wind Mode
- ⑦ Reverse
- ⑧ FAN/OFF
- ⑨ FAN 4-hour Timer
- ⑩ FAN 2-hour Timer