

Warning:

This product must be installed by personnel who are familiar with its structure and related hazards, in accordance with the installation specifications. This product is suitable for indoor installation.

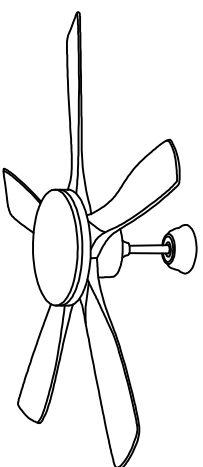

Product style diagram

Steps of installation

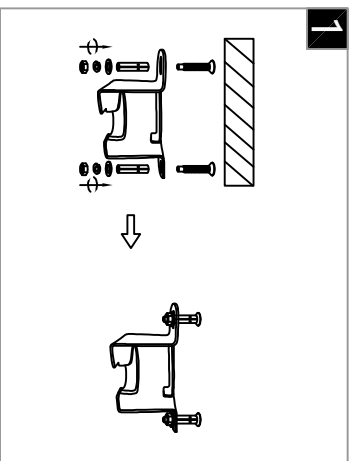

Note: The ceiling must be able to bear a weight of 20 IBS. Then, follow the steps below to fix the mounting plate onto the ceiling.

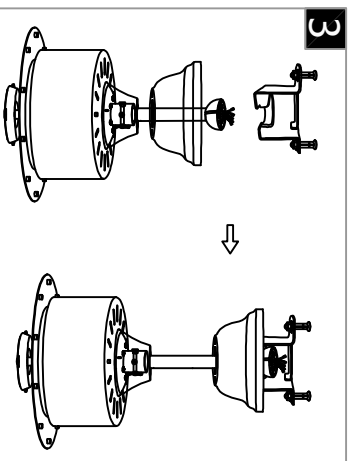

Insert the connection rods of the lamp body into the suspension bracket one by one, then put the power driver into the top cover, and insert the reserved driving wire into the connection rods.

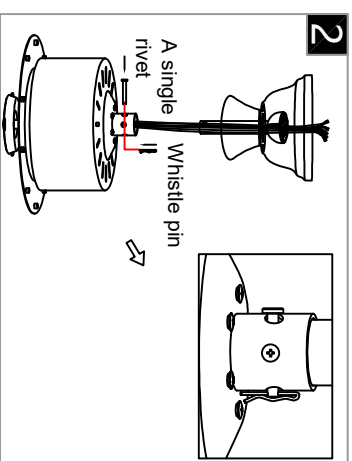

Insert the wires on the motor from the connecting rod into the driver by color, then press the entire lamp body onto the motor, insert the iron pin, and tighten the screw.

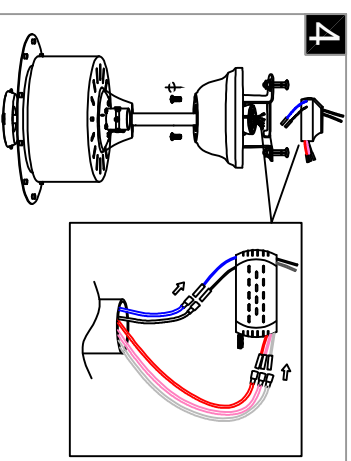

Insert the connection rods of the lamp body into the mounting plate one by one, then put the power driver into the top cover, and insert the reserved driving wire into the connection rods.

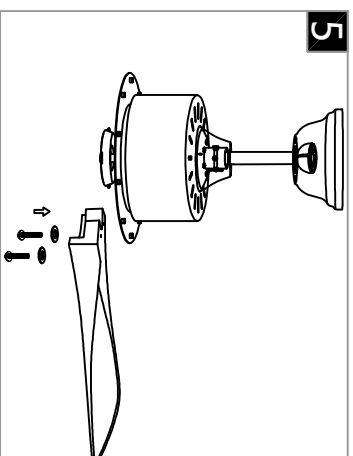

Lock the fan blades onto the fan motor according to their serial numbers, paying attention to the front and back of the fan blades. Then lock the screws.

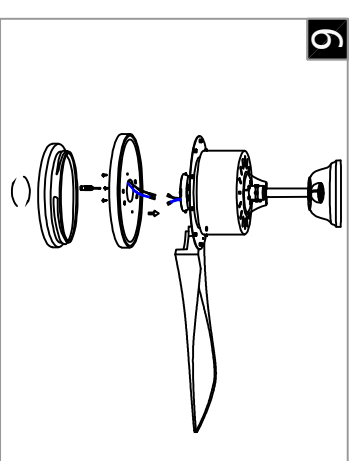

Connect the wires on the light source cover to the wires on the motor by color, align the screw holes on the motor with the light source cover, and then fix the screws with a screwdriver. Then twist the acrylic lampshade clockwise over the light source lampshade.

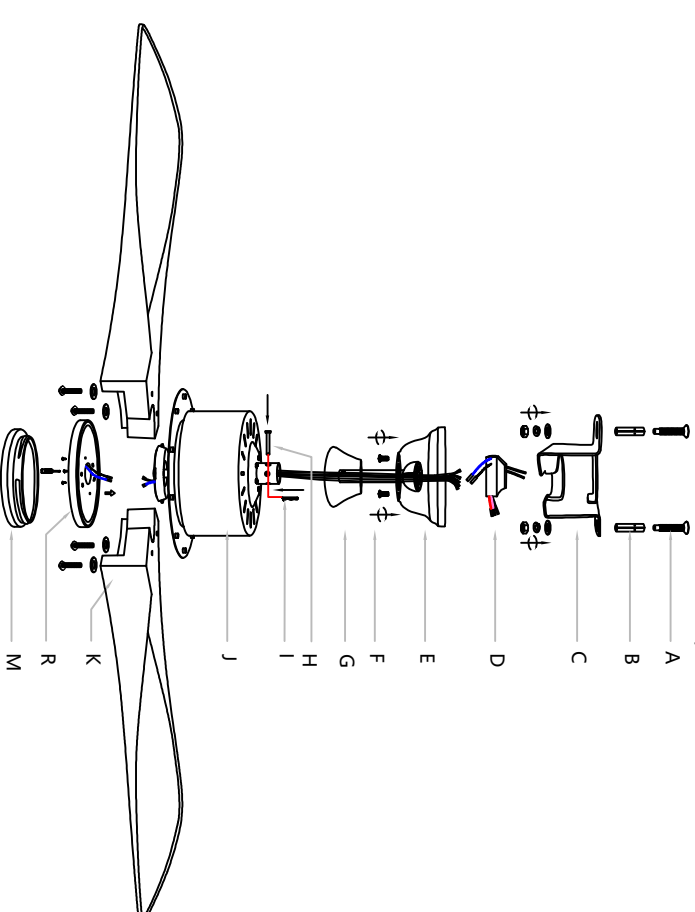

Install the fan blade (K) to the motor (J) with screws and shims, then insert the wire above the light source cover (R) into the motor (J) according to the color, then align the hole above the light source cover (R) with the hole of the motor (J), lock the screw, and then twist the light source cover (M) clockwise to the light source cover (R). Then use the connecting rod (F) to align the motor (J) mouth from the lamp cover (E) down, then put the wire on the motor (J) through the bottom cover (G) and the connecting rod (F) into the top cover (E), then use the pin (H) to align the connecting rod (F) and the motor (J) hole and insert, and then use the pin (I) to insert the iron pin (H) down. Then use the iron pin (B) to cover the screw (A) and then drive into the ceiling, then use the mounting plate (C) to align the screw (B) and then use the nut and gasket to lock it, then use the lamp body connecting rod (F) head to hang in the mounting plate (C), and then connect the wire on the lamp body to the power driver (D) according to the color. Then connect the neutral wire and hot wire above the power drive (D) to the wire above the ceiling. It is best to align the bottom hole of the top cover (E) with the hole on the mounting plate (C) and then lock the screw