

**Warning:**  
This product must be installed by personnel who are familiar with its structure and related hazards, in accordance with the installation specifications. This product is suitable for indoor installation.

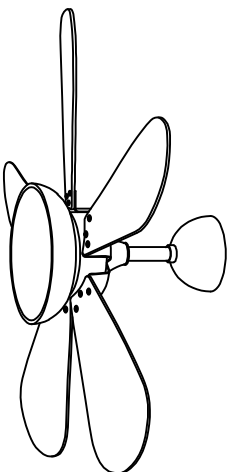

Product style diagram

Steps of installation

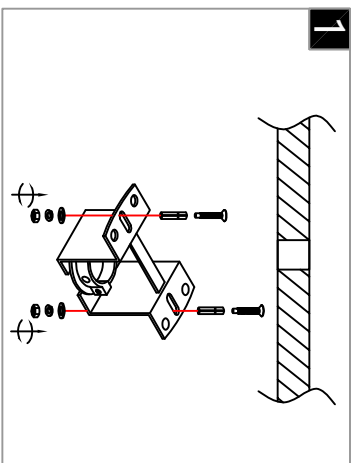

Install the bracket onto the ceiling.

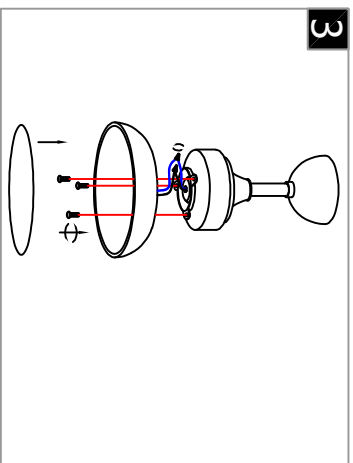

Pass the light source wire through the hole of the disc, use the connector cap to connect the wire of the motor, attach the light source inside the disc, then align the hole of the disc with the hole under the motor, tighten the screws, and insert the lampshade into the disc.

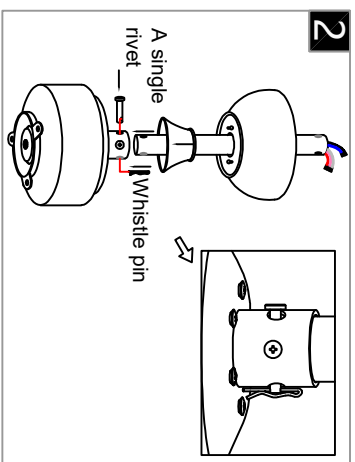

Insert the round tube into the cylinder on the motor, align the holes, insert the lock pin, then insert the pin into the lock pin, tighten the screws, and push down the horn cover to cover it.

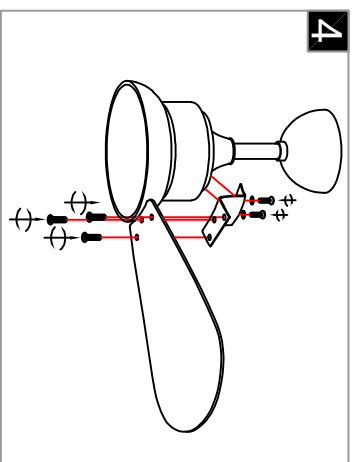

Align the holes of the fan blade with those of the bracket, tighten the screws, and then align the holes of the bracket with those on the motor, and tighten the screws.

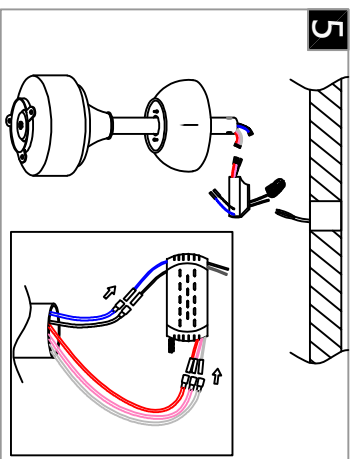

Insert the top cover into the round tube, align the connection ports on the power driver with the extended connection ports on the round tube, and use the terminal block to connect the wires of the power driver to the wires on the ceiling.

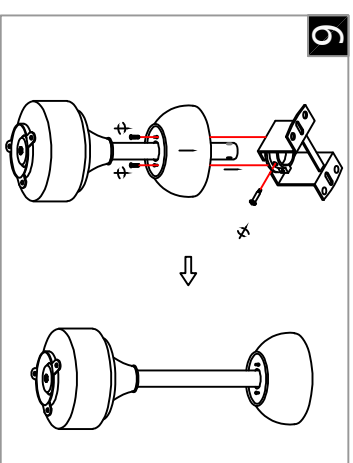

Align the holes of the round tube with those of the fixing device, tighten the screws, and insert the power driver into the installation bracket, align the holes of the top cover with those of the installation bracket, and tighten the screws.

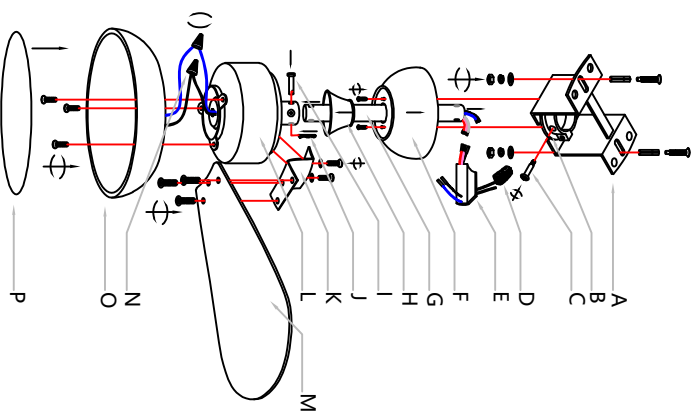

First, insert the round tube (G) into the cylinder on the motor (L), align the holes, insert the lock pin (I), then insert the pin (J) into the lock pin (I), tighten the screws, and push down the horn cover (H) to cover it. Next, pass the light source wire through the hole of the disc (O), use the connector cap (N) to connect the wire of the motor (L), attach the light source inside the disc, then align the hole of the disc (O) with the hole under the motor (L), tighten the screws, and insert the lampshade (P) into the disc. Then, align the holes of the fan blade (M) with those of the bracket (K), tighten the screws, and then align the holes of the bracket (K) with those on the motor (L), and tighten the screws. Next, install the bracket (A) onto the ceiling, then insert the top cover (F) into the round tube (G), align the connection ports on the power driver (E) with the extended connection ports on the round tube (G), and use the terminal block (D) to connect the wires of the power driver (E) to the wires on the ceiling. Then, align the holes of the round tube (G) with those of the fixing device (B), tighten the screws (C), and insert the power driver (E) into the installation bracket (A), align the holes of the top cover (F) with those of the installation bracket (A), and tighten the screws.

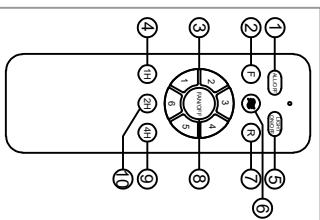

- ① ALLOFF
- ② Forward
- ③ FAN Speed control gears 1-6
- ④ FAN 1-hour Timer
- ⑤ LIGHT ON/OFF
- ⑥ Natural Wind Mode
- ⑦ Reverse
- ⑧ FAN/OFF
- ⑨ FAN 4-hour Timer
- ⑩ FAN 2-hour Timer