

Warning:

This product must be installed by personnel who are familiar with its structure and related hazards, in accordance with the installation specifications. This product is suitable for indoor installation.

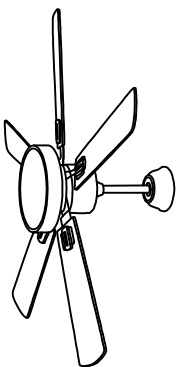

Product style diagram

Steps of installation

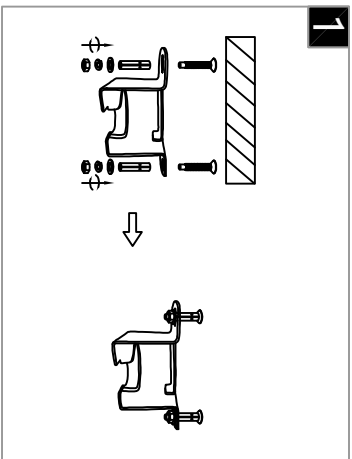

Note: The ceiling must be able to bear a weight of 20 lbs. Then, follow the steps below to fix the mounting plate onto the ceiling.

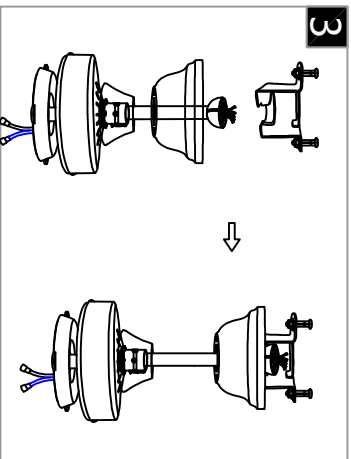

Insert the connection rods of the lamp body into the suspension bracket one by one, then put the power driver into the top cover, and insert the reserved driving wire into the connection rods.

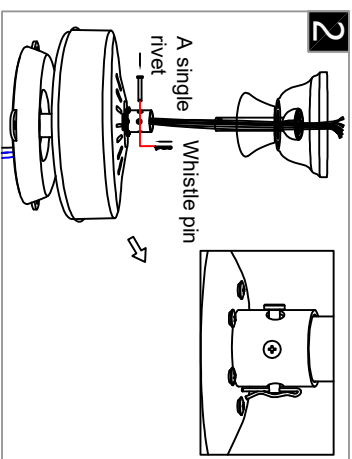

Insert the wires on the motor from the connecting rod into the driver by color, then press the entire lamp body onto the motor, insert the iron pin, and tighten the screw.

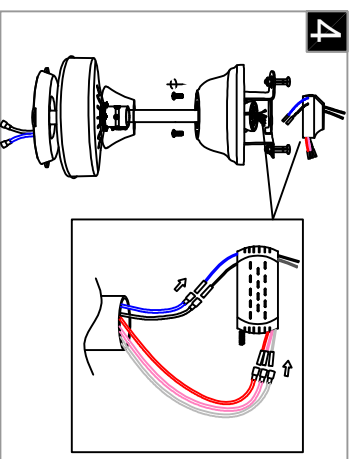

Insert the connection rods of the lamp body into the mounting plate one by one, then put the power driver into the top cover, and insert the reserved driving wire into the connection rods.

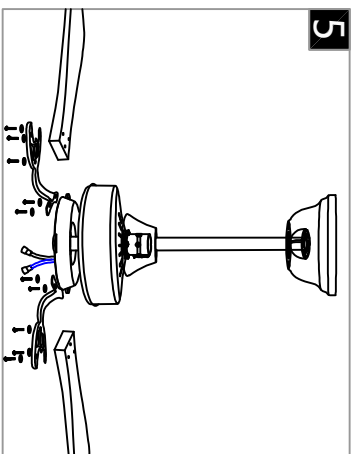

First, install the fan blades onto the fan frame, and then secure it to the motor.

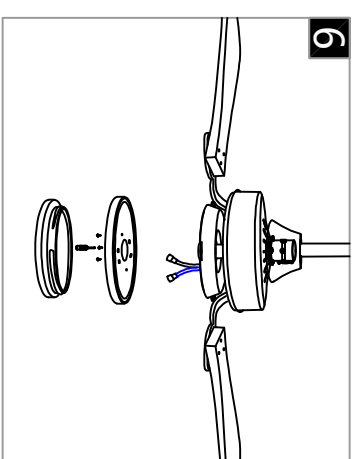

Use screws to secure the light source cover onto the motor, and then screw the light source housing onto the light source cover.

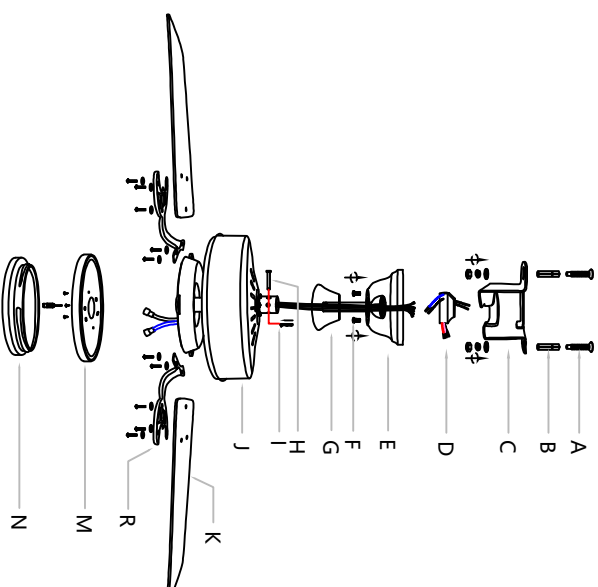

Fix the fan blades (K) to the fan bracket (R) and the motor (J) using screws and washers. Then, attach the light cover (M) to the motor (J) with screws, and then screw the light cover (M) onto the light housing (N). Next, thread the wires through the bottom cover (G) and the connecting rod (F), and insert them into the top cover (E). Align the holes on the connecting rod (F) and the motor (K) with the pins (H), and then insert the pin (I) into the iron pin (H). Cover the screw (A) with the iron pin (B) and screw it into the ceiling. Align the screw (B) with the mounting plate (C), and lock it with a nut and washer. Next, use the head of the light body connecting rod (F) to suspend the light body on the mounting plate (C), and connect the wires on the light body to the power driver (D). Connect the neutral and live wires above the power driver (D) to the wires above the mounting plate (C), and then tighten the screws. Then, thread the connecting rod (F) and the motor (K) through the bottom cover (G) and the connecting rod (F), and insert them into the top cover (E). Align the holes on the connecting rod (F) and the motor (K) with the pins (H), and then insert the pin (I) into the iron pin (H). Put a screw (A) over the iron pin (B), and screw it into the ceiling. Align the screw (B) with the mounting plate (C), and lock it with a nut and washer. Next, use the head of the light body connecting rod (F) to suspend the light body on the mounting plate (C), and connect the wires on the light body to the power driver (D). Connect the neutral and live wires above the power driver (D) to the wires above the mounting plate (C). It is best to align the holes at the bottom of the top cover (E) with the holes on the mounting plate (C), and then tighten the screws.