

Warning:
This product must be installed by personnel who are familiar with its structure and related hazards, in accordance with the installation specifications. This product is suitable for indoor installation.

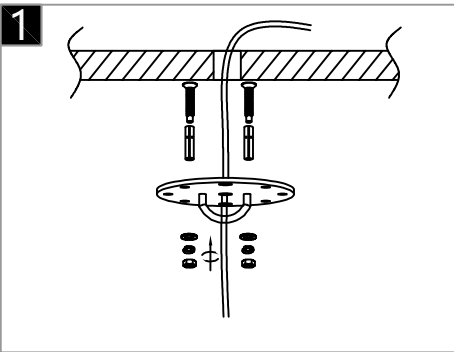

Product style diagram

Steps of installation



First, fix the expansion screws onto the ceiling, and then lock the mounting plate onto the screws.

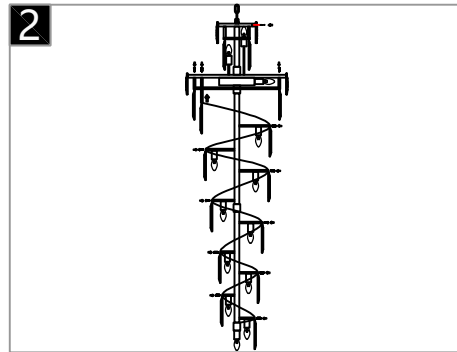

Install the lamp body shelf according to the corresponding size, and then put the lamp body wire through the chain to the top cover reserved, and then connect the chain to the top cover and the lamp body

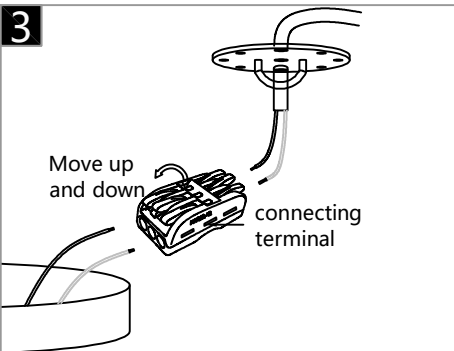

Connect the wires inside the luminaire and ceiling to the terminal, usually neutral wire (white), hot wire (black)

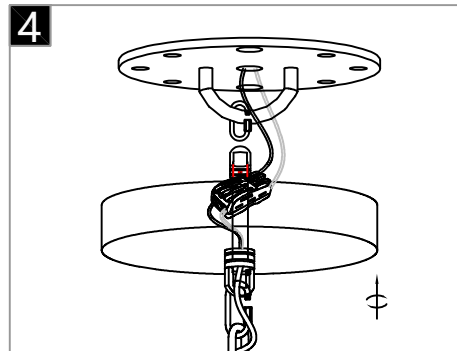

Lock the clasp to the hook on the lamp cover and mounting plate, then tighten the screws

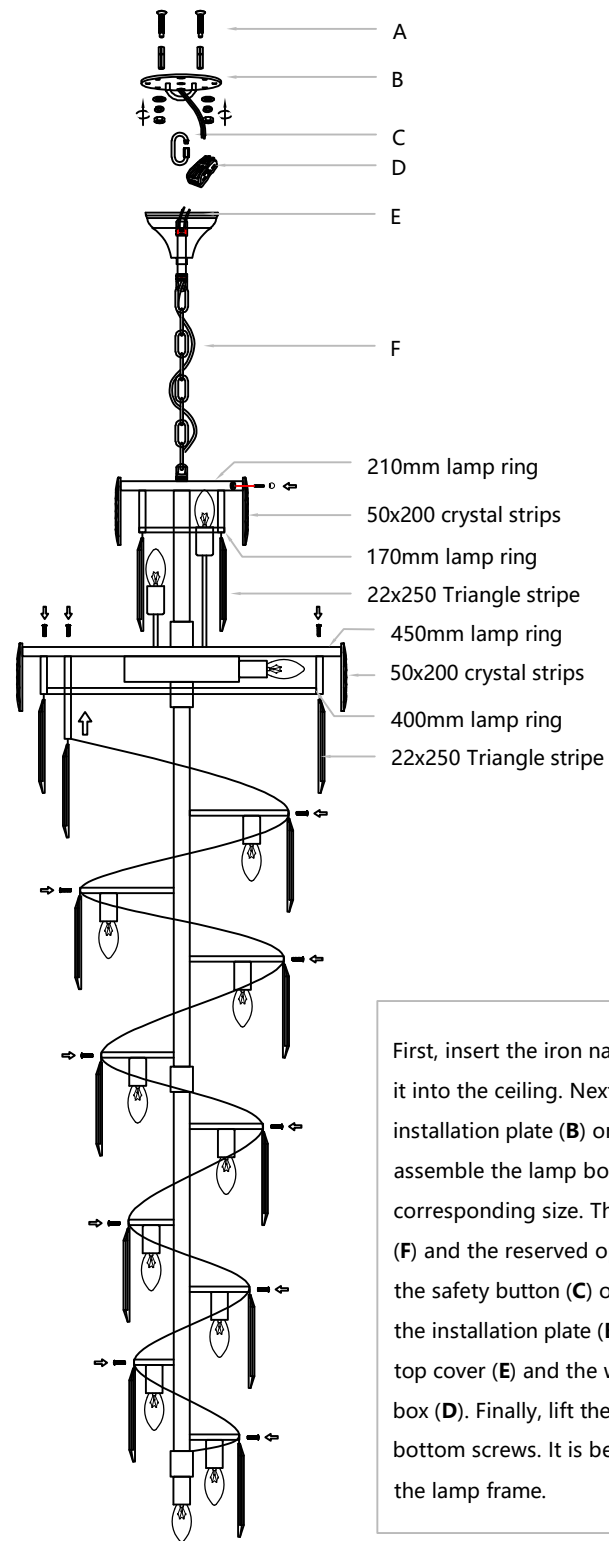

First, insert the iron nail into the screw (A), and then screw it into the ceiling. Next, use the screw and washer to fix the installation plate (B) onto the screws on the ceiling. Then, assemble the lamp body frame together according to the corresponding size. Then, pass the wires through the chain (F) and the reserved opening on the top cover (E). Then, fix the safety button (C) on the top cover (E) onto the hook on the installation plate (B). Then, connect the wires on the top cover (E) and the wires on the ceiling to the junction box (D). Finally, lift the top cover (E) up and tighten the bottom screws. It is best to install the crystal sheet onto the lamp frame.